



— Molecular Imaging Products Company —

Principles of the Anesthetic Machine

**This training pamphlet was a result of a collaborative effort with
Marcelo Couto, DVM, The Scripps Research Institute, La Jolla, California
and Jim Houts, OmniMed Inc., Bend, Oregon**

Molecular Imaging Products Company
62971 Plateau Drive, Suite 300
Bend, Oregon 97701
800-877-8989

www.MIPcompany.com

Principles of the Anesthetic Machine

The anesthetic machine dispenses the gases that are necessary to induce sleep and prevent pain to animals during surgical procedures or other potentially painful manipulations.

The basic anesthetic delivery system consists of a source of oxygen (O₂), an O₂ flowmeter, a precision vaporizer, which produces a vapor from a volatile liquid anesthetic, a patient breathing circuit (tubing, connectors and valves), and a scavenging device that removes any excess anesthetic gases. This is critical, since room pollution with anesthetic gases may lead to health problems in animals as well as in humans.¹

During delivery of gas anesthesia to the patient, O₂ flows through the vaporizer and picks up the anesthetic vapors. The O₂-anesthetic mix then flows through the breathing circuit and into the patient's lungs, usually by spontaneous ventilation (respiration). Occasionally, it is necessary to use assisted ventilation, especially when opening the chest (thoracic) cavity. Assisted ventilation is accomplished by use of a ventilator or respirator.

OXYGEN SUPPLY O₂ may be provided by a central distribution system or by pressurized tanks (cylinders). Medical grade gases are color-coded. Oxygen cylinders are green in the United States. Oxygen tanks come in various sizes. The two most common are portable "E" tanks, which contain about 660 liters of O₂ at 1,900 PSI (pounds per square inch), and large stationary "H" tanks, which hold 6,900 liters of O₂ at 2,200 PSI.

Portable "E" tanks are connected to the anesthetic machine by one or two hanger yokes. Proper connection is essential to avoid leaks. The "E" tank assembly on the anesthesia machine contains various pins whose position is peculiar for each gas. This is a safety device to prevent connection of the wrong cylinder to the anesthetic machine. The pins on the machine must match and fit snugly into the holes on the head of the cylinder by use of a single plastic gasket or O-ring (supplied with each new tank).

Since portable and stationary cylinders store gas at very high pressure (2,000 PSI), a pressure-reducing valve or regulator is required to reduce the pressure to about 50 PSI, which is a level that can easily be handled by the flowmeter. Further reduction in pressure is achieved by adjusting the flowmeter control knob for safe delivery of gas to the patient. Central pipeline pressure is usually set at about 50 PSI of pressure for delivery to multiple anesthesia machines.

As O₂ is consumed with regular use, the pressure within the tanks declines linearly. The regulator adjusts automatically when the pressure inside the cylinder falls as the gas is used. When the pressure reaches 500 PSI, an "E" tank contains approximately 175 L of O₂ and should be replaced.

¹The purpose of gas-scavenging systems is to eliminate waste anesthetic gases (WAGs) from the work area to minimize breathing by personnel. Waste gas-capture devices include direct exhaust to the outside through an outside wall, or a direct connection to the building exhaust system. WAGs may be eliminated via an active (i.e., vacuum driven) or passive (outside wall, activated charcoal F-Air® canister) system. Pollution may occur during chamber induction, maintenance of anesthesia by loose facemask or nose cone, discharge of waste gases from a breathing circuit into the room, and spillage or vapor escape when filling the vaporizer. To reduce pollution when using an induction chamber, scavenge the chamber adequately. When the animal is anesthetized, quickly remove it from the chamber and replace the lid.

OXYGEN FLOWMETER This device uses an adjustable needle valve to deliver the desired flow in ml or liters per minute to the patient circuit. Flows of around 0.5-2 liters of O₂ per minute are commonly used with rodent anesthesia machines. Flowmeters are individually calibrated for a specific gas, e.g., oxygen or nitrous oxide. Flow is read from the middle of the indicator metal ball on the graduated scale.

ANESTHETIC VAPORIZER Precision vaporizers produce an accurate gaseous concentration from a volatile liquid anesthetic. The dial or knob on the vaporizer can be adjusted so that the precise percentage of anesthetic gas leaving the vaporizer is known. Modern vaporizers, such as those provided by Molecular Imaging Products Company (MIP), are accurate at oxygen flow rates of 0.3 L/min up to 15 L/min and automatically adjust the anesthetic concentration to compensate for ambient temperature fluctuations. These precision instruments must be serviced and calibrated every 1-3 years, depending on the degree of use.

The Portable Anesthetic Machine (PAM), consisting of O₂ flowmeter, vaporizer, and common outlet for rodent anesthesia is shown in the Appendix.

PATIENT BREATHING CIRCUIT The patient breathing circuit is the highway for anesthetic gas delivery to the patient. The goals of an anesthetic breathing circuit are to:

- A. Deliver oxygen to the patient
- B. Deliver anesthetic to the patient
- C. Remove carbon dioxide that is produced by the patient
- D. Provide a method for assisting or controlling ventilation, if needed

The non-rebreathing system (or Bain circuit; Figure 1, next page) commonly used in rodent anesthesia uses very high fresh gas flows that deliver the anesthetic gas and washes out the exhaled CO₂. This setup contains an exhaust hose to scavenge and evacuate excess anesthetic gases. The basic design of the Bain circuit comprise a narrow bore tubing that delivers fresh gases (oxygen and anesthetic) to the patient; a wide bore tubing that collects exhaled gases, and its continuation into a corrugated tubing that leads to a scavenging activated charcoal F/Air canister (see below). These circuits are ideally suited for anesthesia of rodents, small birds and other small species.

SCAVENGING SYSTEMS These systems are designed to absorb or eliminate waste anesthetic gases (WAGs) to prevent or minimize room pollution; WAGs may be exhausted to the outside or may be directed to absorbent materials, such as activated charcoal (F/Air Canisters²).

² The weight of the F/Air® canister must be recorded upon installation and the canister should be replaced after a weight increase of 50 grams; this indicates that its capacity to absorb halogenated anesthetics has been exhausted. Alternatively, the canister should be replaced after twelve hours of anesthesia time at an O₂ flow rate of 2 liters per minute. Halogenated anesthetics include isoflurane, halothane, enflurane, desflurane, sevoflurane and methoxyflurane. Please note that F/Air® canisters do not absorb other anesthetic gases, such as nitrous oxide (N₂O). When in use, F/Air® canisters should be placed in a position so as not to occlude the bottom, e.g., on a wire holder or on their side.

Molecular Imaging Products Company
62971 Plateau Drive, Suite 300
Bend, Oregon 97701
800-877-8989

www.MIPcompany.com



Figure 1. Patient breathing circuit used for rodent anesthesia

When the oxygen is turned on, the gas flow is continuous, as follows:

O₂ CYLINDER → REGULATOR FLOWMETER → VAPORIZER → PATIENT BREATHING CIRCUIT → SCAVENGING SYSTEM

POTENTIAL PROBLEMS WITH BAIN CIRCUITS The O₂ flow rate should be around 3 times the patient's minute ventilation.³ In practical terms, O₂ flow should be no less than 500 ml (0.5 liters) per minute. When anesthetizing mice in the induction chamber, the O₂ flow must be increased to approximately 1.5-2 liters per minute. Insufficient flow rates may allow CO₂ to be re-breathed and cause respiratory acidosis. Because of this characteristic, non-rebreathing systems utilize a great deal of O₂ when compared to rebreathing systems used in larger species.

Because there is no rebreathing, Bain circuits deliver high flow of dry cool gas to the patient, which causes significant body heat and humidity loss. Small rodents are therefore prone to becoming hypothermic and dehydrated. It is therefore essential to place rodents on a heating surface or near a heat source, especially during prolonged procedures. When using a heating blanket or heat lamp, the operator must ensure that the animals are not exposed to excessive heat, which may drop the blood pressure and/or cause skin burns. In addition, anesthetized animals have impaired thermoregulation. A humidifier may be used to add moisture to the gases in the patient breathing circuit.

³ Minute ventilation is the volume of air that ventilates the lungs in one minute. It is calculated by multiplying the tidal volume (air moved in and out of the lungs with each breath) by the respiratory rate (200-300 breaths/minute in the awake mouse). For example, the tidal volume of a 25-g mouse is approximately .25 ml (1% of its body weight). The minute ventilation for this mouse would be approximately 50 ml (500cc per minute = O₂ flow rate). During isoflurane anesthesia, the respiratory rate is markedly decreased to about 25-50 breaths/min and the depth of each respiration is increased. Much of the gases that flow into the patient never reach the lung alveoli, i.e., where the actual exchange of O₂ and CO₂ occur. Much air occupies the space between the nose and the alveoli in the lungs: this is known as "anatomical dead space". Another significant portion of the fresh gases occupy the tubes and adapters between the anesthetic machine and the nose: this is called 'mechanical dead space'. Both the anatomical and the mechanical dead spaces are excluded from the gas exchange process and therefore must be added to the calculation of tidal volume and minute ventilation.

Molecular Imaging Products Company
62971 Plateau Drive, Suite 300
Bend, Oregon 97701
800-877-8989

www.MIPcompany.com

GETTING STARTED - INDUCING AND MAINTAINING ANESTHESIA

Anesthesia may be induced in a single animal or in several rodents at the same time by use of an induction chamber.

1. Anesthetizing a single mouse or rat

An individual mouse may be anesthetized by placing it in an induction chamber (recommended) or by holding the animal's nose firmly inside the nose cone adapter. Rats are anesthetized by placing them individually in an induction chamber.

For either method:

1. Verify that there is sufficient O₂ in the tank(s) to last until the end of the planned procedure. Replace the "E" tank if the pressure gauge reads < 500 PSI. Centrally supplied O₂ should be monitored.
2. Verify that there is sufficient isoflurane in the vaporizer by checking the fluid level through the glass window (site glass).

When using an induction chamber:

3. Check all connections and make sure that the inflow to the chamber (from the vaporizer's common outlet) and its outflow (to the F-Air canister or evac system) are in the open position. Make sure the back of the patient breathing circuit is connected to a second F-Air canister
Note: the connections between the anesthetic machine and the patient breathing circuit are color coded for ease of operation, to avoid potentially dangerous consequences to the animal and to minimize room pollution)
4. Close the flow to the Bain circuit nose cone.
5. Place the animal inside the chamber and close the lid tightly.
6. Turn on the O₂ source and set the fresh gas flow into the chamber at 1 to 2 liters per minute (LPM) using the flowmeter control knob.
7. Turn on the vaporizer and adjust the isoflurane concentration to 4-5% (lower % for sick or old animals; use 3.4% when in doubt)
8. When the animal is in a moderately deep plane of anesthesia (lying on its side and breathing rhythmically) remove it from the chamber and close the lid.
9. Connect its nose to the Bain circuit's nose-cone adapter (or face mask) and open the gas flow to the nose cone
(Note: since mice and rats are obligate nose-breathers, it is not essential to include the mouth in the nose cone)
10. Adjust the O₂ flow to 0.5 LPM and reduce the isoflurane concentration to 2.5-3.0% (or lower to maintain surgical plane of anesthesia)

Molecular Imaging Products Company
62971 Plateau Drive, Suite 300
Bend, Oregon 97701
800-877-8989

www.MIPcompany.com

11. Monitor the depth of anesthesia throughout the procedure⁴.
12. When finished with the procedure, shut off the isoflurane vaporizer and maintain the O₂ flow to the animal until it wakes up.
13. Shut off O₂ flow at the tank if using an E tank; or disconnect from the O₂ supply if centrally provided.
14. Return the animal to its cage⁵.
15. Check the flowmeter to verify that the O₂ flow has ceased and turn the flowmeter control knob to the OFF position (fully closed clockwise).

When holding the mouse against the nose cone:

1. Follow steps 1 and 2 above.
2. Turn on the O₂ source and set the fresh gas flow into the Bain circuit at 1 liter per minute (LPM) using the flowmeter control knob.
3. Hold the mouse by the scruff with its nose firmly against the opening of the NRB circuit. For induction, it may be helpful to secure the tubing to the edge of the working surface by using tape or other methods. The nose cone may then be repositioned to the desired location.
4. Turn on the vaporizer and adjust the isoflurane concentration to 4-5% or lower depending on the age and condition of the mouse.
5. Once the mouse offers no resistance to the manual restraint and is able to lie on its side or back, adjust the O₂ flow to 0.5 LPM and reduce the isoflurane concentration to 2.5-3% depending on the procedure being performed (or lower to achieve surgical plane of anesthesia).
6. Follow steps 11-15 above.

2. Anesthetizing a group of mice

Several mice may be anesthetized as a group in the induction chamber and maintained individually on a nose cone during the desired procedure. One animal at a time may be removed from the induction chamber and connected to the Bain circuit. By use of the dual diverter valve the anesthetic flow may be diverted to either the chamber or the individual animal, or be allowed to flow in both directions simultaneously.

⁴ Anesthesia must be monitored from the time of induction to full recovery. An animal is considered to have recovered from anesthesia when it is fully awake and able to rest on its belly. The effectiveness of monitoring depends on the physiologic parameters chosen. Commonly used variables include: respiration rate and pattern, heart rate, color of the footpads, and response to toe-pinch reflex and painful manipulations. Respiratory rate changes from fast during induction to more slow and rhythmic as the depth increases. Heart rate follows a similar pattern. In addition to respiration and heart rate, the operator must monitor other parameters, such as toe-pinch reflex (leg withdrawal) and color of the footpads (pink in most rodents).

⁵ Rodents recovering from anesthesia should be placed *by themselves* or with other *similarly anesthetized* animals in a *clean* cage lined with gauze or paper towels to prevent injuries and accidental inhalation of bedding material (aspiration pneumonia).

Molecular Imaging Products Company
62971 Plateau Drive, Suite 300
Bend, Oregon 97701
800-877-8989

www.MIPcompany.com

1. Follow steps 14 above.
2. Turn on the O₂ source and set the fresh gas flow into the chamber at 2 liters per minute (LPM).
3. Place the mice inside the chamber and close the lid tightly.
4. Turn on the vaporizer and adjust the isoflurane concentration to 4-5% or lower, if indicated.
5. When the mice are moderately anesthetized remove one mouse from the chamber and immediately close the lid.
6. Connect its muzzle to the Bain circuit's nose-cone adapter (or face mask) and open the gas flow to the nose cone.
7. Maintain gas flow at 2 LPM to supply both the nose cone and the chamber.
8. Reduce the vaporizer setting to a maintenance level of 2.5 to 3 % isoflurane (or lower).
9. Recover each mouse by shutting off the flow of anesthetic to the Bain circuit and allowing the animal to breathe room air. Return the animal to its cage when awake.
10. Continue to remove one mouse at a time from the chamber and proceed as described above for the first mouse.
11. At the end of the procedures, shut off the vaporizer and close the valve to the Bain circuit.
12. Flush the chamber to minimize atmospheric pollution by increasing O₂ flow to the chamber (keep the lid closed!) to about 4-5 LPM and allowing the O₂ to displace the anesthetic gas from the chamber into the F/Air canister (or evac system) attached to the chamber
13. Shut off the O₂ at the tank and wait until the flowmeter reads 0 (zero).
14. Close the flowmeter.

The main problem associated with chamber induction is the potential for room pollution and personnel exposure to inhalation anesthetics. This occurs when the chamber is opened to introduce or remove animals. For this reason, it is advisable to keep the chamber in a well-ventilated location. When using the nose cone, it is important that it fit snugly over the rodent's muzzle to prevent leakage of anesthetic gases.

Troubleshooting the anesthetic machine

The most common problem with anesthetic machines is leaks. Leaks commonly occur around tubing connections, flow valves and O₂ yokes. It is imperative that any leaks be corrected since they can waste gas and/or expose the operator to high levels of anesthetic vapors.

Molecular Imaging Products Company
62971 Plateau Drive, Suite 300
Bend, Oregon 97701
800-877-8989

www.MIPcompany.com

See the next pages for Diagrams of Systems

Molecular Imaging Products Company
62971 Plateau Drive, Suite 300
Bend, Oregon 97701
800-877-8989

www.MIPcompany.com

Components of the Rodent Anesthetic Machine

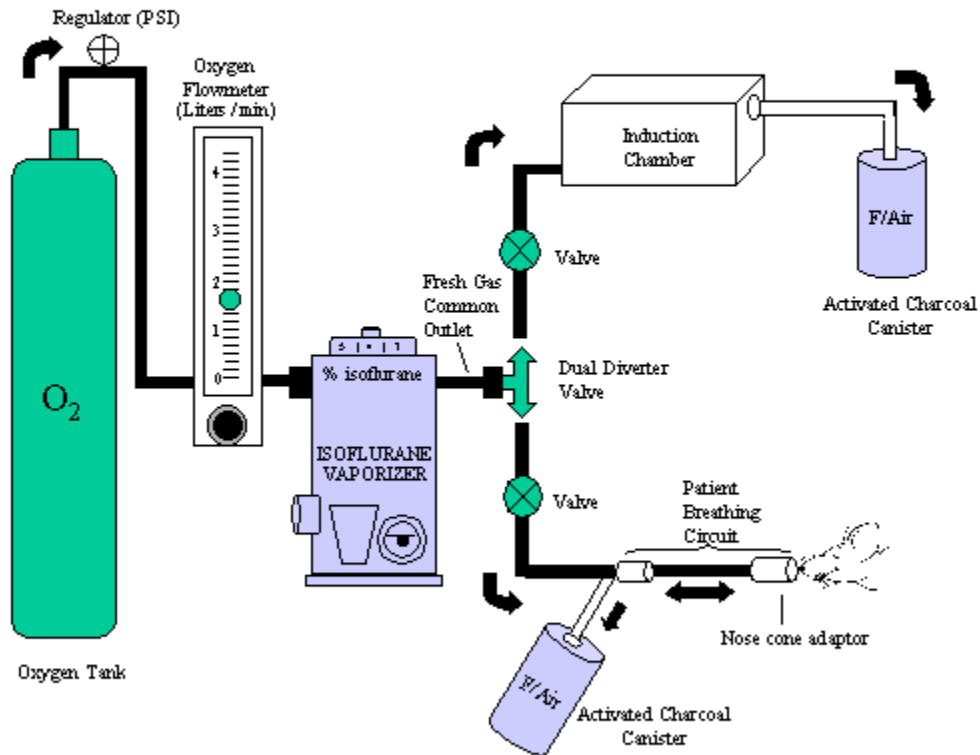

Molecular Imaging Products Company
62971 Plateau Drive, Suite 300
Bend, Oregon 97701
800-877-8989

www.MIPcompany.com

Components of the Rodent Anesthetic Machine

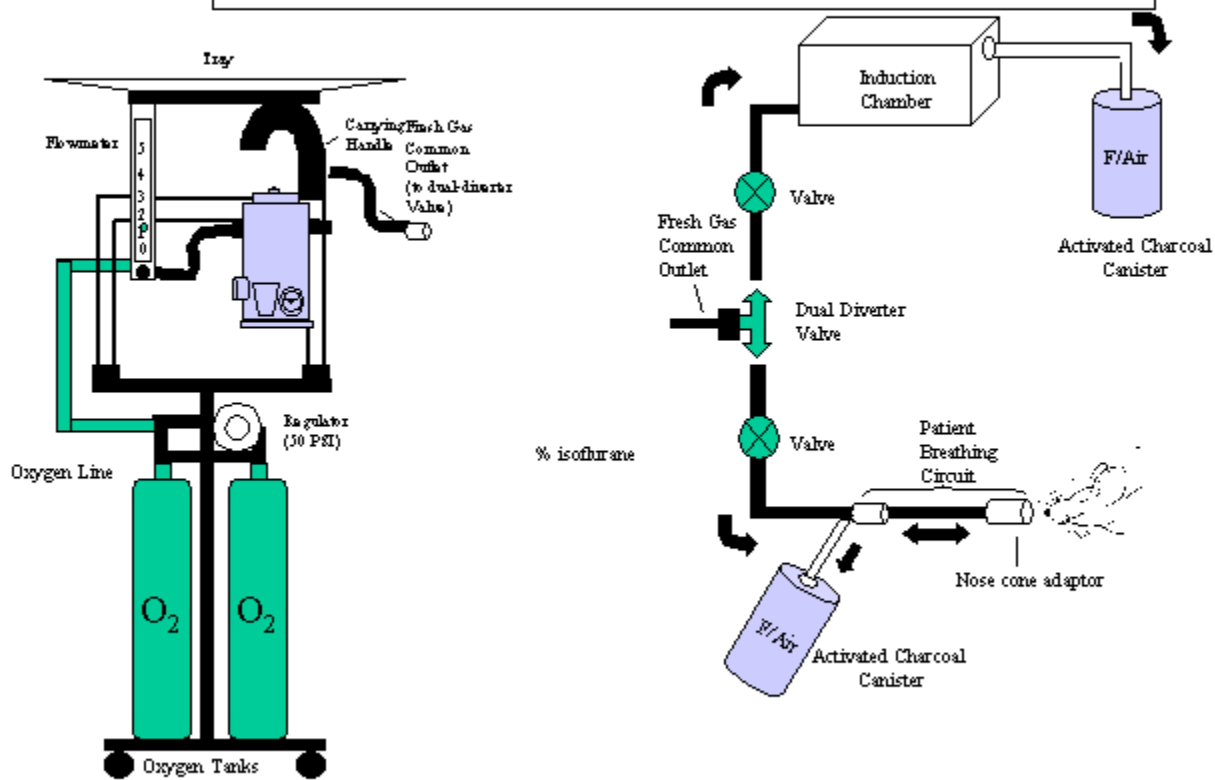

Molecular Imaging Products Company
 62971 Plateau Drive, Suite 300
 Bend, Oregon 97701
 800-877-8989

www.MIPcompany.com

Components of the PAM

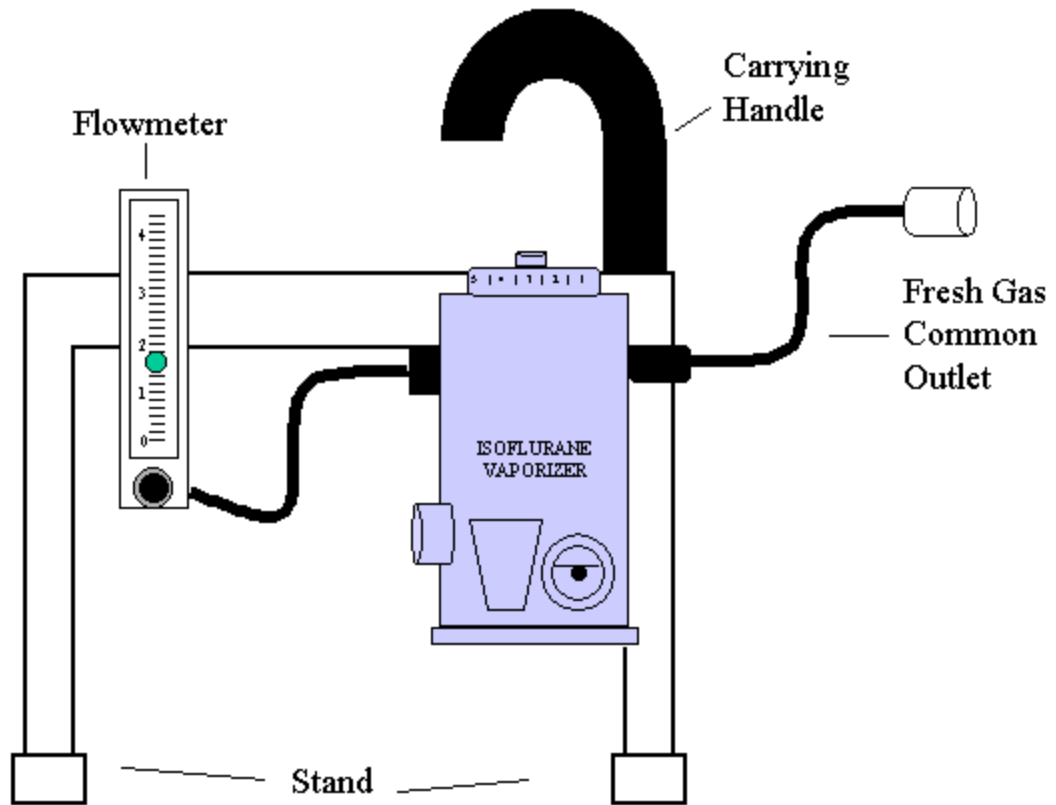

Molecular Imaging Products Company
62971 Plateau Drive, Suite 300
Bend, Oregon 97701
800-877-8989

www.MIPcompany.com

Quality Assurance Checklist
For Summit Anesthesia Solutions System (Qualitative Tests)

I. Leak Test High Pressure System (Oxygen tank to back of O₂ flowmeter)

- A. Turn off O₂ flow control.
- B. Turn on O₂ tank.
- C. Watch tank pressure gauge needle stabilize and note PSI.
- D. Turn off O₂ tank.
- E. Watch pressure gauge needle. If needle drops, you have a leak. The bigger the leak, the faster the needle drops.
 - 1. If needle drops 50 PSI in one minute, look for leaks.
 - a. Windex can be use on fittings. If Windex bubbles, you have a leak. Tighten fitting.
 - 2. If needle does not drop 50 PSI in one minute, proceed with further testing as follows:

II. Leak Test Low Pressure (O₂ flowmeter to common outlet)

- A. Turn on O₂ tank.
- B. Put thumb over common outlet.
- C. Turn on O₂ Flowmeter to one liter per minute flow (with vaporizer off).
 - 1. Watch float in flowtube.
 - a. If no leak, ball will drop slightly and pressure will build-up on thumb.
 - 2. If float does not drop and pressure does not build-up on thumb, check:
 - a. All tubing for cracks and proper connections.
 - b. Inlet and outlet adapters to ensure they are properly positioned into vaporizer.
- D. Turn on O₂ Flowmeter to one liter per minute flow (with vaporizer on).
 - 1. Watch float in flowtube.
 - a. If no leak, ball will drop slightly and pressure will build-up on thumb.
 - 2. If float does not drop and pressure does not build-up on thumb, check:
 - a. Fill cap of vaporizer to ensure it is tightly sealed.
 - b. Stop is positioned properly in pin-indexed vaporizer

Molecular Imaging Products Company
62971 Plateau Drive, Suite 300
Bend, Oregon 97701
800-877-8989

www.MIPcompany.com

- III. If your machine is equipped with a rebreathing head (carbon dioxide absorbent canister), please do the 10 second test as follows:

10 SECOND TEST

Before each use, "leak check" the machine, and also ensure that the waste gases have a patent way through your evacuation system

1. Close pop-off valve and cover the Y-piece with your palm or thumb.
2. Hit oxygen flush or turn on oxygen until the bag is distended.
3. Turn the oxygen off and watch the manometer, or the bag if your machine does not have a manometer.

If the manometer reading drops rapidly, or the bag deflates rapidly, or if you hear a hissing sound, you have a leak.

4. Check hoses, bag, vaporizer inlet and outlet, any screw down fittings, and the seals at the top and bottom of your soda sorb container for leaks. When the pressure remains fairly constant with the oxygen turned off, your machine can be considered leak free on the low pressure side.
5. Reopen the pop-off to your usual setting.
6. Squeeze the bag (with your thumb still over the Y-piece) to ensure the gases have a patent way out through your scavenging system.

If there appear to be leaks in the system, which you cannot identify nor eliminate, please call MIP for repair.

Molecular Imaging Products Company
62971 Plateau Drive, Suite 300
Bend, Oregon 97701
800-877-8989

www.MIPcompany.com